



(12) **EUROPEAN PATENT APPLICATION**

(43) Date of publication:
13.10.2021 Bulletin 2021/41

(21) Application number: **21167474.2**

(22) Date of filing: **08.04.2021**

(51) Int Cl.:
E04B 5/12 (2006.01) **E04C 3/12 (2006.01)**
E04C 3/18 (2006.01) **E04B 2/70 (2006.01)**
E04C 3/36 (2006.01) **E04C 3/29 (2006.01)**
E04C 3/292 (2006.01)

(84) Designated Contracting States:
AL AT BE BG CH CY CZ DE DK EE ES FI FR GB GR HR HU IE IS IT LI LT LU LV MC MK MT NL NO PL PT RO RS SE SI SK SM TR
 Designated Extension States:
BA ME
 Designated Validation States:
KH MA MD TN

(30) Priority: **08.04.2020 IT 202000007471**

(71) Applicant: **Plushaus S.r.l.**
20822 Seveso (MB) (IT)

(72) Inventor: **FERRARA GRANAI, Fausto**
20822 Seveso (MB) (IT)

(74) Representative: **Santi, Filippo et al**
Barzanò & Zanardo Roma S.p.A.
Via Piemonte 26
00187 Roma (IT)

(54) **LINEAR MODULE FOR BUILDINGS FOR THE MAKING OF STRUCTURAL FRAMES OF PREFABRICATED BUILDINGS WITH THERMAL INSULATION, KIT FOR BUILDINGS AND PREFABRICATED BUILDING THEREOF**

(57) This invention relates to a linear building module (70; 71) for making structural frames of thermally insulated multi-storey buildings, comprising an upper face, a lower face, substantially parallel to said upper face, and four lateral faces, said linear module (70; 71) comprising: an inner body (10) comprising a plurality of structural elements (11; 12) spaced apart from each other so as to form a plurality of cavities, said structural elements (11; 12) comprising at least two perimeter elements (11) arranged on respective opposing lateral faces of said linear module (70; 71); filling elements (20) made of thermally insulated material, placed in said plurality of cavities so as to fill them; and at least two outer cover elements (30', 30'') for covering said body (10) and said filling elements (20) at said lower face and said upper face, respectively, said cover elements (30', 30'') being blocked, by means of blocking means, to said body (10) so as to form a self-supporting element.

This invention also relates to a kit comprising at least two linear building modules (70; 71) and to a multi-storey building formed by such linear modules (70; 71).

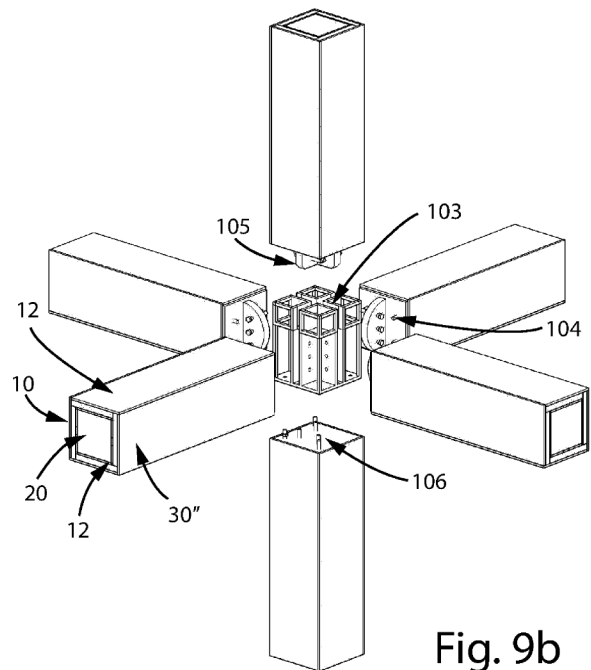

Fig. 9b

Description

[0001] This invention relates to a linear building module for the making of structural frames of buildings, in particular prefabricated buildings with thermal insulation, building kit comprising such module and building thereof.

[0002] More specifically, this invention relates to a linear building module for the making of multi-storey prefabricated buildings, in particular made of wood, having a high energy efficiency.

[0003] This invention also relates to a multi-storey building constructed using such building modules.

[0004] As is well known, the growth of the world's population and the increased urbanisation of cities requires improvements in construction efficiency, both in terms of the speed at which buildings are constructed and in terms of environmental sustainability. In particular, efforts continue to be made to improve the ecological sustainability of new buildings, minimising the waste of the planet's resources and related CO2 emissions.

[0005] Such issue is all the more pressing in view of the dramatic increase in the demand for housing. For example, more than forty million young people are looking for an independent and stable housing solution in Europe alone.

[0006] However, with current building systems, it would not be possible to meet such demand, both in terms of the time required to build homes and the exploitation of natural resources and the high costs involved.

[0007] In order to overcome these problems, several systems for the construction of buildings have been proposed.

[0008] An example of such systems is described in European Patent No. EP 2 920 377 B1.

[0009] In particular, such document describes a method of constructing buildings by means of planar-shaped expanded polyurethane (EPS) blocks locked together by means of an external wooden frame, wherein the elements of such external frame are glued, blocked or screwed together with long wood screws so as to lock the EPS block in place.

[0010] However, such construction elements have the following disadvantages:

- poor torsional rigidity and bending strength;
- they do not allow the construction of buildings with more than four storeys;
- it is not possible to use these elements with linear or sectional structures, such as beams or pillars, as the elements that are locked together have little compactness and are in fact disconnected as a whole.

[0011] Other systems are also known which involve making panels or boxes or caissons to form walls, wherein an insulated material is covered on both sides by wood or wood fibre (OSB) material or metal. The resulting panels are generally referred to as 'SIPs' (Structural Insulated Panels). However, these panels are made in such a

way as to ensure only good thermal resistance and may be used in a limited number of constructions, as they do not have sufficient resistance to vertical loads to allow the construction of multi-storey buildings using them.

[0012] Additionally, several systems for the construction of prefabricated multi-storey buildings, in particular wooden prefabs, have been developed over the years.

[0013] Generally, such systems involve the use of load-bearing walls which may or may not be subsequently insulated. Among these construction systems, those that can be assembled using the 'frame' method and those that can be assembled using the 'panel' method are known.

[0014] The 'frame' method involves the use of a structure of vertical wooden uprights coupled with additional horizontal wooden elements.

[0015] The 'panel' method on the other hand, involves the construction of multi-storey buildings through the use of load-bearing walls or septa made of lamellar wood with layers that are criss-crossed and coupled together during construction.

[0016] In order to facilitate the assembly of such structures, the Applicant has proposed, in Italian Patent Application No. 102015000077457 (ITUB20155972A1), energy-efficient structural shells for making vertical wooden walls, capable of supporting adequate vertical loads according to the intended use.

[0017] In particular, such structural shells consist of a single, seamless element wherein an insulated material may be arranged.

[0018] However, the parts of the building that are to be placed horizontally or inclined may not be constructed with such structural shells. In particular, it is not possible to build slabs or other building coverings, rather it is necessary to interface them with other structural elements, such as beams, generally made of wood, in order to support the vertical loads also in such an arrangement, especially in the case of building slabs with large spans.

[0019] Finally, a number of prefabricated elements are known for the construction of buildings in a time- and cost-efficient manner. Such prefabricated elements usually have pre-assembled dimensions and can be made of steel, concrete or both materials combined.

[0020] By way of example, known prior art document no. US 10 196 809 B2 describes a method which allows the construction of multi-storey buildings by means of a system of septa for the formation of floors or load-bearing slabs in a steel lattice structure. Such method allows the structure of a multi-storey building to be built quickly but requires subsequent insulation to be applied after the building has been constructed to make it energy efficient.

[0021] In addition, such prefabricated elements have the disadvantage of being extremely heavy, bulky and difficult to transport and install.

[0022] Further relevant documents of the background art are European Patent Application No. EP 0 237 044 A1, Patent Application No. US 4 187 655 A, Patent Application EP 2 149 645 A1 and Patent Application US 8

161 699 B2. However, none of these solutions have optimal structural features that would allow the formation of energy-efficient multi-storey buildings.

[0023] A further example of prefabricated modules of known art is described in WO 2015/071821 A1.

[0024] The aim of this invention is to provide a building module which is able to overcome the drawbacks of the background art.

[0025] In particular, the aim of this invention is to provide building modules for the construction of multi-storey modular buildings.

[0026] Furthermore, it is an aim of this invention to provide a construction kit comprising such building modules for the construction of energy-efficient buildings.

[0027] Moreover, it is the aim of this invention for such modules to be easy to use and replace.

[0028] Further, it is an aim of this invention for such building modules to be used for all building elements, i.e. both for the construction of vertical elements, such as walls or pillars, and for the construction of horizontal or inclined elements, such as slabs, beams, floors or other possible coverings.

[0029] Again, the aim of this invention is for such modules to be economical, both in terms of production costs and the costs of transport, installation, repair, maintenance and replacement.

[0030] A further aim of this invention is for such building modules to allow the construction of slabs and large glass surfaces, while at the same time providing excellent thermal insulation and extreme lightness when compared to building modules of the background art.

[0031] Finally, it is the aim of this invention for such system to have less of an environmental impact than systems of the background art.

[0032] Therefore, an object of this invention is a linear building module for making structural frames of thermally insulated multi-storey buildings as defined in appended claim 1.

[0033] Such linear module may have the features claimed in the relevant dependent claims 2-8.

[0034] A further object of this invention is a kit comprising at least two linear modules for making a structural node of said structural frame.

[0035] In particular, such kit may have the features as defined in the attached claims 9-14.

[0036] Finally, a multi-storey building as defined in claim 15 is a specific object of this invention.

[0037] According to one aspect of the invention, a building module (whether a linear module and/or a panel) for making a thermally insulated multi-storey building comprises an upper face, a lower face, substantially parallel to said upper face, and four lateral faces. In particular, said module comprises:

a body comprising a plurality of structural elements spaced apart from each other so as to form at least one cavity, said structural elements comprising at least two perimeter elements arranged on respective opposing lateral faces of said module; at least one filling element

made of thermally insulated material, placed in said at least one cavity so as to fill it; and at least two outer cover elements for covering said body and said at least one filling element at said lower face and said upper face, respectively, said cover elements being blocked, by means of blocking means, to said body so as to form a self-supporting element and responding to local stresses.

[0038] According to such aspect of the invention, the structural elements of said body may comprise a plurality of substantially flat slabs arranged transversely between said lower face and said upper face of said building module, each slab being capable of having a dimension equal to a length of said building module. In particular, said slabs may be arranged parallel to each other and spaced apart from each other so as to form said perimeter elements and one or more dividing septa of said cavities.

[0039] Further, according to such aspect of the invention, said structural elements of said body may comprise slabs made of micro-lamellar wood, laminated wood, or plywood.

[0040] Further, according to such aspect of the invention, said structural elements of said body may comprise reinforcing elements made of metal or other material, for example steel, said reinforcing elements being preferably flat or tubular elements or lattice elements, for example hot-drawn or cold-drawn lattice elements.

[0041] Specifically, said reinforcing elements may be coupled to said slabs, for example with a single or double coupling.

[0042] Also according to such aspect of the invention, said building module may comprise transversal elements arranged transversely to said structural elements.

[0043] In particular, said transversal elements may cover two further lateral faces of said building module, thus connecting said perimeter elements.

[0044] Further, according to such aspect of the invention, said at least one filling element made of thermally insulated material may be made of expanded polyurethane, extruded polyurethane, wood fibre, cork, straw, or with a thermally insulated multilayer material.

[0045] Furthermore, according to such aspect of the invention, said cover elements may be wood fibre cladding, OSB cladding, plywood cladding or cement fibre cladding, while said transversal elements, when present, may be made of micro-lamellar wood or may be steel plates.

Further, according to such aspect of the invention, such body may be combined with another body containing systems and services with a prefabricated finish cladding.

[0046] Finally, according to such aspect of the invention, at least two facing lateral faces may have profiles with complementary curvatures.

[0047] A further aspect of this invention is a kit comprising at least two building modules of the said type and coupling means for coupling said two building modules, said coupling means being preferably clamping elements, in particular steel clamping elements, plates for

beams or for pillars, or bolts.

[0048] Another aspect of this invention is a thermally insulated multi-storey building comprising vertical surfaces and horizontal surfaces, in particular walls, pillars, slabs or beams, made by means of building modules or by means of a kit of the said type.

[0049] A final aspect of this invention is a method of assembling a building module of the said type, comprising the following steps:

- A. blocking, by means of blocking means, said structural elements on a first cover element so as to form said lower face, said body with said at least one cavity and two lateral faces of said building module;
- B. inserting said at least one filling element into said at least one cavity, filling it; and
- C. covering said body and said at least one filling element with a second cover element, arranged substantially parallel to said first cover element, and fixing said second cover element to said body, preferably compressing said at least one filling element, i.e. acting as a contrast to the actions imparted by said first cover element.

[0050] The invention is now described, by way of example and without limiting the scope of the invention, with reference to the accompanying drawings, wherein:

Figure 1 a shows an axonometric view of a building constructed using building modules according to this invention;

Figure 1b shows an axonometric view of a structural frame of a building constructed by means of building modules according to this invention, comprising linear modules for making the structural frame and horizontal and vertical panels constrained to such linear modules;

Figure 1c shows a detail of Figure 1b, comprising the structural frame and its panels;

Figure 2 shows a partial exploded view of a building module according to this invention, for forming a linear module and/or a panel;

Figure 3 shows a perspective view of a plurality of building panels assembled to form a wall and slab and the coupling means between such modules;

Figure 4 shows a detail of Figure 3;

Figure 5 shows a perspective view of a plurality of building panels comprising reinforcing means, such panels being assembled together by means of their coupling means;

Figure 6 shows a perspective view of a modular system comprising a building module according to this invention, for making linear modules and/or panels, coupling means between modules and reinforcing means of said modules;

Figure 7 shows an exploded perspective view of a building module according to this invention, for making linear modules and/or panels, comprising rein-

forcing means, in particular steel cross members; Figure 8 shows an axonometric view of building panels on conventional beams and pillars not forming part of this invention;

Figure 9a shows an axonometric view of linear modules according to this invention, forming a structural node, comprising pillars and beams, arranged in an orthogonal cross, creating a load-bearing frame system;

Figure 9b shows an exploded view of the linear modules in Figure 9a;

Figure 10 shows an exploded axonometric view of a coupling element for the linear modules according to this invention, for forming a structural node;

Figure 11a shows an application example of building panels, assembled to form curved walls;

Figure 11b shows a perspective view of building panels assembled to form a horizontal surface; and

Figure 12 shows a perspective view of building panels assembled with a suspended ceiling, both prefabricated and modular.

[0051] With particular reference to Figures 1-12, numerical reference 70, 71 is assigned to linear building modules according to this invention, and numerical reference 1 or 1b or 1c is assigned to panels that can be coupled to such linear modules.

[0052] In particular, the expression building module 1; 1b; 1c; 70; 71 is used to refer to any module configured for the construction of the different parts of multi-storey prefabricated buildings with high thermal efficiency performance.

[0053] In fact, both the linear modules 70; 71 and the panels 1, 1b, 1c can have the same structural features, differing only in their shape.

[0054] In particular, each building module 1; 1b; 1c; 70; 71 comprises an upper face, a lower face parallel to said upper face and four lateral faces. Each building module 1; 1b; 1c; 70; 71 may consist of elements that can be assembled either in the workshop or on site. As shown in the figures, such building module can be a six-faced rectangular parallelepiped, in particular a smooth rectangular parallelepiped without any particular recesses or indentations. Such shape is particularly advantageous as it allows the formation of buildings and structures in less time than in the case of construction using interlocking modules, where care must be taken in the choice of modules to be used.

[0055] In particular, each building module 1; 1b; 1c; 70; 71 comprises:

- a body 10 made by means of a plurality of elements 11, 12 spaced apart from each other so as to form a plurality of cavities;
- insulated filling elements 20 made of low-density thermal insulated material, placed in the cavities of said body 10 in such a way as to fill them, preferably being compressed therein; and

- two cover elements 30', 30" which cover said insulated filling elements 20 and said body 10 at said upper face and of said lower face, respectively, said cover elements 30', 30" being blocked on said body 10 by means of blocking means.

[0056] Such coupling between the body 10 and the cover elements 30', 30" is particularly advantageous as it makes it possible to obtain a self-supporting element with good resistance to possible stresses in the various directions.

[0057] In particular, the structure shown in Figures 1a and 1b can be made exclusively using building modules 1; 1b; 1c, 70, 71 by first making the structural frame by means of the linear modules (in particular beams 71 and pillars 70), and subsequently coupling it to infill panels 1 to create load-bearing perimeter closure walls, to horizontal load-bearing panels 1b to make slabs, and/or to horizontal cladding panels 1c, for example to make the roof.

[0058] Advantageously, such structure can be built more quickly than structures made with the modules of the background art, as structural frames can be formed using the linear or sectional modules 70, 71 (i.e. beams and pillars) that are already insulated and are fire-resistant according to the current fire resistance class REI 240.

[0059] As shown in Figures 2-7, the body 10 of each module 1, 1b, 1c, 70, 71 may be made from a plurality of substantially flat slabs 11 arranged parallel to each other and transverse to said lower face and said upper face.

[0060] In particular, the slabs 11 may have the same length as said building module 1; 1b; 1c; 70; 71 and may be spaced apart from each other so as to form a plurality of vertical cavities.

[0061] In addition, two respective slabs 11 can form two opposite lateral faces of the building module 1; 1b; 1c, 70, 71.

[0062] Said body 10 can be made of wood or steel or both materials.

[0063] In order to improve the structural properties of such body 10 while minimizing the weight of the building modules 1; 1b; 1c; 70; 71, such body 10 may comprise said wooden slabs 11 together with steel reinforcing elements 12 coupled to said wooden slabs 11, for example tubular or lattice-shaped steel reinforcing elements 12 that may have been hot-drawn or cold-drawn.

[0064] In the case of linear modules 70; 71, the reinforcing elements 12 may be made of steel or other material.

[0065] In this case, the reinforcing element 12 may also have a box shape or be traceable to commercially available profiles such as HEA, IPE and similar, which are also insulated with EPS or similar foam. Furthermore, the linear modules 70; 71 can be enclosed within box-shaped elements, for example made of insulated material covered in material such as fibre cement, REI panels, finishing panels or anything else, to form an additional

cavity.

[0066] In this way, it is possible to form a plurality of box-shaped elements, for example with coinciding small faces, arranged one inside the other, wherein said further cavity can be advantageously intended for the passage of corrugated system conduits having a small diameter, for example connectable to the systems in the non-load-bearing panels 1, 1c, as illustrated in greater detail below.

[0067] In any case, due to the conformation of the building modules 1; 1b; 1c; 70; 71, the reinforcing elements 12 may have a reduced cross-section compared to the cross-section of said slabs 11.

[0068] The slabs 11 and the reinforcing elements 12 may have the same height H in order to increase the mechanical resistance of the respective building module 1; 1b; 1c; 70; 71 and to facilitate their coupling with linear or sectional structural elements, in particular linear modules 70; 71 for the formation of pillars 70 or beams 71.

[0069] In addition, the width L of the slabs 11 of the body 10 is preferably equal to that of the reinforcing elements 12. Preferably, the peripheral slabs 11 have a greater width than the width of the body 10 so as to create shelf-bound systems, for coupling with further building modules 1; 1b; 1c; 70; 71.

[0070] The reinforcing elements 12 in the body 10 may be in the form of a frame so as to stiffen the edges of the building module 1; 1b; 1c; 70; 71, thus increasing its static and mechanical features so as to support transverse and torsional stresses. Referring in particular to Figure 7, such frames made with the reinforcing elements 12 may comprise transverse tie bars 101 along the whole width of the building modules 1; 1b; 1c; 70; 71.

[0071] Further, each element 11, 12, 101 of the body 10, in particular each slab 11, preferably has a thickness of at least 1/8 of the total thickness of the building module 1; 1b; 1c to be formed. By way of example, if the building module 1; 1b; 1c is 30 cm thick, the thickness of each slab 11 is approximately 4 cm.

[0072] In case the body 10 also comprises reinforcing elements 12, the latter may preferably have a thickness of at least 1/20 of the total thickness of the building module 1; 1b; 1c; 70; 71 to be formed.

[0073] For example, in the case of building modules 1; 1b; 1c; 70; 71 with said thickness of 30 cm, each reinforcing element has a thickness of approximately 1.5 cm.

[0074] Thus, in the case of a single coupling between slab 11 and reinforcing element 12, the total thickness of the coupled elements of said body 10 may be at least about 1/5 of the total thickness of the relevant building module 1; 1b; 1c; 70; 71. Similarly, in the case of a double coupling between a slab 11 and two reinforcing elements 12, the total thickness of the coupled elements of said body 10 may be about 1/4 of the total thickness of the building module 1; 1b; 1c; 70; 71.

[0075] In the example of building modules 1; 1b; 1c having a total thickness of approx. 30 cm, the thickness of said single-coupled elements is approx. 5.5 cm, while the thickness of said double-coupled elements is approx.

7 cm.

[0076] In particular, a single coupling means a coupling between a slab 11, preferably made of wood, and a reinforcement 12, while a double coupling means a coupling between a slab 11, preferably made of LVL, and two reinforcements 12 placed at the sides of said slab 11. Preferably, the reinforcements 12 are flat steel reinforcements in both cases.

[0077] As mentioned above, the slabs 11 can be micro-lamellar wood (LVL) slabs 11 or laminated wood or plywood or other environmentally sustainable material, while any reinforcing elements 12 can be made of steel or other alloy and can be flat or tubular or box-shaped elements or hot- or cold-drawn steel lattice elements.

[0078] Further, the slabs 11 preferably cover at least two outer sides of each building module 1; 1b; 1c; 70; 71, preferably two outer sides parallel to each other.

[0079] Furthermore, even more preferably, the slabs 11 covering said two outer sides can be connected by means of a transversal reinforcing element 50 placed in said building module 1; 1b; 1c; 70; 71 or at the remaining outer sides of said building module 1; 1b; 1c; 70; 71 in order to support the transversal forces exerted by the wind and/or earthquakes.

[0080] The thermically insulated filling elements 20 may be made of low-density, high heat-resistant material such as expanded polyurethane, extruded polyurethane, wood fibre, cork, straw or other materials of natural origin, or of two or more multilayer materials with low density and high resistance to thermal conduction.

[0081] These materials can in fact completely fill said cavities, preferably being compressed inside them, so that the filling elements 20 can also have a containing function, as well as a thermal insulation function.

[0082] Preferably, the compression direction is from a first cover element 30' to a second cover element 30".

[0083] Expanded polyurethane (EPS) is particularly suitable for such use as it gives the filling element 20 solidity and excellent energy efficiency features.

The use of expanded polyurethane guarantees optimal thermal performance and allows the formation of building modules 1; 1b; 1c; 70; 71 that are extremely lightweight as compared to the background art.

[0084] In addition, the modules 1; 1b; 1c; 70; 71 formed in this way have excellent resistance to transverse, bending and torsional loads.

[0085] Thanks to such features, the building module 1; 1b; 1c; 70; 71 thus formed can also be used with traditional linear structures 700 made of steel or reinforced concrete, as shown in Figure 8, or with linear modules 70, 71, as shown in Figures 1a, 1b, 9a, 9b and 10 and as better illustrated below.

[0086] Each insulated filling element 20 preferably has two parallel faces having the same width L and the same height H as the inner and outer faces of each slab 11 of said body 10, said insulated filling elements 20 further having a thickness substantially equal to the distance of a first slab 11 of said body 10 from the next slab 11, so

that said insulated filling elements 20 remain embedded in the cavities.

[0087] In addition, thermically insulated filling elements 20 can advantageously be used as additional stiffening to the body 10, preventing it from bending and torsional stresses.

[0088] In other words, the filling elements 20 can be made of low-density thermal insulated material such as expanded polyurethane (EPS).

[0089] Consequently, the building panels 1, 1b, 1c and the linear modules 70, 71 are advantageously insulated due to the presence of thermically insulated materials.

[0090] The cover elements 30'; 30" of each building module 1; 1b; 1c; 70; 71 can be clad with wood fibre material or OSB (Oriented Strand Board) wood or wood cement (fibre cement) cladding, or with plywood or fibre cement, the latter making the block fireproof and protected against water and weathering.

[0091] Therefore, the cover elements 30'; 30" can be made to form an outer structural skin made of wood fibre or OSB (Oriented Strand Board) wood or plywood or wood fibre or cement fibre.

[0092] The building module 1; 1b; 1c; 70; 71 may be made by blocking, by means of clamping means, each slab 11 of said body 10 to a first cover element 30' so as to form a self-supporting element, and by interposing an insulated filling element 20, in particular a rectangular parallelepiped-shaped filling element 20, between two consecutive slabs 11.

[0093] The body 10 and the insulated elements 20 thus coupled are finally covered by the further cover element 30".

[0094] In addition, each building module 1; 1b; 1c; 70; 71 may be made so as to be particularly lightweight, when compared with other building modules of known art. In fact, since the body 10 can be made of micro-lamellar wood (LVL) or wood, with optionally the addition of said reinforcing elements 12 made of steel with reduced cross-section, the final weight of each building module 1; 1b; 1c; 70; 71 is advantageously reduced compared to the modules of known art. In addition, a structural frame built using such building modules 1; 1b; 1c; 70; 71 has the known advantages of being a dry system.

[0095] Each building module 1; 1b; 1c; 70; 71 may preferably have a thickness varying between 150 mm and 500 mm, a width varying between 200 mm and 2500 mm and a length varying between 1000 mm and 18000 mm.

[0096] In any case, the total dimensions of each building module 1; 1b; 1c; 70; 71, i.e. its width L1, its height H1 and its thickness S1, can be appropriately chosen according to the requirements of the construction drawings, e.g. generated by means of BIM (Building Information Modelling). In particular, the width L1 can be dimensioned on site by cutting the filling elements 20 along a longitudinal direction so that the cavities of the body 10 can be filled when it is built.

[0097] Each building module 1; 1b; 1c; 70; 71 can be used in the construction of a high energy performance

multi-storey building.

[0098] In particular, the building modules 1; 1b; 1c; 70; 71 can be advantageously used to make:

- multi-storey buildings with full-light glazed infills;
- multi-storey buildings with very large rooms with no inner walls;
- buildings on pilings;
- pergolas; and
- greenhouses,

as explained in more detail below.

[0099] In fact, once formed, the building modules 1; 1b; 1c; 70; 71 can be coupled to each other by means of coupling means, such as structural wood screws or bolted steel brackets, as shown in Figures 3-10.

[0100] In particular, the brackets allow the building panels 1a; 1b; 1c to be used in conjunction with various traditional construction elements, such as sectional elements like pillars and beams 70; 71, whether they are filled with steel or reinforced concrete reinforcements.

[0101] The wood screws may preferably be arranged in the shape of a cross, screwed onto an inner face of each building module 1; 1b; 1c; 70; 71 to be coupled, or they may be structural wood screws 90, in particular long wood screws 90, so as to couple each building module 1; 1b; 1c; 70; 71 transversely across their full width or according to other anchoring methods.

[0102] Finally, the building panels 1; 1b; 1c may be coupled to the structural frame by means of steel elements 60 through clamping components 100, as shown in Figure 8, or by means of a steel clamping system 103 coupled to appropriate plates 104, 105 at the ends of the building module 1; 1b; 1c; 70; 71 itself, as shown in Figures 9a and 9b.

[0103] In addition, said transverse reinforcements 50, which may be made of micro-lamellar wood (LVL), may be placed at the ends of the building modules 1; 1b; 1c. As mentioned, such transverse reinforcements 50 can also be accommodated in the cavities of modules 1; 1b; 1c themselves to increase their resistance to horizontal and torsional forces, such as a gust of wind and an earthquake.

[0104] As shown in Figures 9a, 9b and 10, the linear modules 70, also referred to as sectional elements 70, can be coupled to each other and/or to the respective building panels 1; 1b; 1c by means of a clamping element 103, 104, 105, 106. In particular, steel clamping elements 103 and/or appropriate first plates 104 for beams or second plates 105, 106 for pillars, for example anchored by bolting, may be used.

[0105] The plates 104, 105, 106 can also be insulated on one or two faces if they are on board the fabricated structure.

[0106] Such linear modules 70 can therefore be coupled together to form a structural node, as shown in Figures 9a, 9b and 10.

[0107] Thanks to this feature, one type of connection

alone can be provided for the formation of different structures, including structural nodes, thus reducing design and production costs and simplifying the assembly and supply of individual elements.

[0108] This makes it possible to industrialise the construction of entire buildings by means of a prefabricated system comprising linear modules 70 of the type described, i.e. comprising lamellar wood and micro-lamellar slabs 11 (e.g. Kerto, LVL) with the possible integration of metal elements in the core, such as nodes made of steel or other material, while varying only the dimensions according to the architecturally required structural pitch and height.

[0109] In addition, linear modules 70, such as beams and pillars, can advantageously have the same insulation as the other building panels 1; 1b; 1c, thus ensuring a homogeneous transmittance value throughout its entire development.

[0110] In particular, the linear modules 70, 71 may comprise insulated material therein, arranged between the individual slabs 11, and/or may be covered with other fireproof material on all faces, including the outer slabs 11.

[0111] In the case of prefabs of known art, wherein the beams and pillars consist of traditional masonry elements with internal metal profiles, there may be a variation in the thermal transmittance values that could lead to evident phenomena of condensation inside the walls of the building, as well as resulting in significantly lower performance and efficiency than the proposed system.

[0112] Finally, thanks to the special shape of the linear modules 70 described above, it is possible to create any type of infill, whether it consists of prefabricated walls, full-length glazed infills or other material.

[0113] Therefore, building modules 1; 1b; 1c; 70; 71 can be advantageously used for the construction of structural elements with large spans.

[0114] Advantageously, the infill can be carried out at any time, at the same time as the installation of the structure in linear modules 70 or later, thus optimising the progress of the work, especially in the event of variations during construction.

[0115] It is well known that variations during construction due to new architectural or plant engineering requirements are difficult to apply without significant costs; the proposed prefabricated system overcomes such a disadvantage.

[0116] In fact, a prefabricated system with a frame structure consisting of insulated structural linear modules 70 connected together on site or in the workshop, makes it possible to use the other building panels 1 as internal and perimeter infills with a non-structural function.

[0117] This means that systems can be easily inserted therein without compromising or affecting the load-bearing structure. For example, it is possible to lay pipes in the building panel 1 during the prefabrication step.

[0118] In the case of modules 1 having a structural function, horizontal passageways must be limited, as

they would interrupt the resistant section in the prefabricated wall and any upgrading of the systems on the installed load-bearing wall would be impossible without affecting the load-bearing capacity of the element itself.

[0119] On the contrary, inserting systems into internal infills with a non-structural function ensures they are easy to maintain. As shown, such systems can be connected by means of elements fed through corrugated conduits arranged in the linear modules 70; 71.

[0120] In this case, the infill panels 1 and/or the horizontal cladding panels 1c can be clad with cover elements on both faces, inside of which systems such as underfloor heating systems or photovoltaic panels are arranged, thus reducing the costs of installation on site and optimising production in the workshop.

[0121] Such cover elements can in turn be removably coupled to the remaining part of the respective panel 1, 1c, as they are replaceable. Therefore, such cover elements can be advantageously detached from the remaining part of the panel 1, 1c in order to replace/upgrade the systems.

[0122] In addition, the clamping elements 103, 104, 105, 106 between modules 1; 1b; 1c; 70; 71 may comprise connecting means to connect the systems in the non-structural panels 1, 1c with the corrugated conduits arranged in the linear modules 70; 71.

[0123] Another added value of the load-bearing frame system made of prefabricated and insulated linear modules 70 is the possibility of repairing the infills locally, as it is also possible to replace some of the modules 1 that form the horizontal walls of the prefabricated building without compromising the load-bearing structure.

[0124] Therefore, with reference to Figures 1b, 1c, 9a and 9b, a building kit can be provided for the formation of a structural frame, comprising at least eight linear modules 70, 71, of which four linear modules 70 are of the vertical type for the formation of pillars, and four linear modules 71 are of the horizontal type for the formation of beams, and associated clamping elements 103, 104, 105, 106. In this way, it is possible to make the structural frame of at least one room, as shown in Figure 1c.

[0125] Such kit may also comprise at least one horizontal load-bearing building panel 1b for the construction of the slab, and/or one horizontal cladding panel 1c for the construction of the roof, and/or an infill panel 1 for the construction of the perimeter walls.

[0126] In this way, a prefabricated building could be constructed by first making the frame by joining several structural nodes made from the linear modules 70, 71 and the horizontal load-bearing panels 1b of such kit, and then attaching the walls or cover elements made from the further infill panels 1 and the horizontal cover panels 1c or by means of glass walls, which act as infills.

[0127] In other words, the structural frame of a thermally insulated building may be achieved by a construction method comprising the step of coupling at least eight linear modules 70; 71 together to form the structural frame of a room.

[0128] In particular, a room made using the kit described above may have a square or rectangular cross-section, with possible diagonal bracing, and vertical and horizontal panels 1, 1b, 1c that act as closure and/or, if necessary, bracing, cooperating with the structural frame.

[0129] Therefore, the relevant thermally insulated building may be made by successively coupling at least one panel to said structural frame for the formation of the slab 1b, a horizontal cover 1c and/or an infill wall 1 of said building.

[0130] As already mentioned, the infill panels 1 and the horizontal cover panels 1c are advantageously removable, e.g. for maintenance, adaptation to new standards, and/or the integration of new systems, without compromising the stability of the building.

[0131] Prefabricated systems of known art, such as the one described in WO 2015/071821 A1, instead require the removal of all the walls above the one to be replaced, and therefore are not as easy to apply as the proposed system. In fact, thanks to the presence of a load-bearing frame, the infill panels 1 and the horizontal cladding panels 1c will always be removable as they are not structural, regardless of the storey of the building involved.

[0132] Thanks to such feature, given that it is a modular system, the shape and/or the façades of a building constructed with the building modules 1; 1b; 1c; 70; 71 can be varied without the need to recalculate and modify the structure as a whole, except in the case of major modifications. In this sense, it would even be possible to vary the number of storeys by removing one or more of the upper modules - thus allowing them to be reused for other buildings - without the need to redesign the remaining underlying part of the initial building and for structural interventions to it.

[0133] Such building modules 1; 1b; 1c; 70; 71 can therefore be disassembled either into their individual elements or as a whole from buildings made from several modules 1; 1b; 1c; 70; 71 formed with each other and reused reassembled in different buildings.

[0134] This represents a completely innovative advantage over known prefabricated buildings, which can only be reassembled according to the same scheme wherein they were assembled.

[0135] In the alternative embodiment shown in Figures 11 and 11b, at least two facing lateral faces 107 of each building panel 1; 1b; 1c may be curved, so that they can be adapted to special construction requirements, for example to create complex, non-orthogonal shapes.

[0136] Finally, as shown in Figures 11 and 12, a cladding can be mounted on each building module 1; 1b; 1c so that once the module 1; 1b; 1c is positioned, it has at least one finished surface.

[0137] The preferred embodiments have been described above and variants to the invention have been suggested, but it shall be understood that the invention may be modified and/or adapted by experts in the field

without thereby departing from the scope of the inventive concept, as defined in the claims herein.

Claims

1. Linear building module (70; 71), in particular a beam or pillar, for making a structural frame of a thermally insulated multi-storey building, wherein said linear module (70; 71) is delimited by an upper face, a lower face, substantially parallel to said upper face, and four lateral faces, said linear module (70; 71) comprising:
 - a body (10) comprising a plurality of structural elements (11; 12), spaced apart from each other so as to form at least one cavity, said structural elements (11; 12) comprising at least two perimeter elements (11) arranged on respective opposing lateral faces of said linear module (70; 71) and reinforcing elements (12);
 - at least one filling element (20) made of thermally insulated material, placed in said at least one cavity so as to fill it; and
 - at least two outer cover elements (30', 30'') for covering said body (10) and said at least one filling element (20) at said lower face and said upper face, respectively, said cover elements (30', 30'') being blocked, by means of blocking means, to said body (10) so as to form a self-supporting element.
2. Linear module (70; 71) according to claim 1, **characterised in that** said structural elements (11, 12) of said body (10) comprise a plurality of slabs (11) arranged transversely between said lower face and said upper face, each slab (11) having a dimension equal to a length of said linear module (70; 71), said slabs (11) being arranged parallel to each other and spaced apart from each other so as to form said perimeter elements (11) and one or more dividing septa of said cavities.
3. Linear building module (70; 71) according to any one of the preceding claims, **characterised in that** said structural elements (11, 12) of said body (10) comprise slabs (11) made of micro-lamellar wood, laminated wood or plywood.
4. Linear building module (70; 71) according to either of claims 2 or 3, **characterised in that** said reinforcing elements (12) are coupled to said slabs (11).
5. Linear building module (70; 71) according to any one of the preceding claims, **characterised in that** said reinforcing elements (12) are steel or concrete reinforcing elements (12).
6. Linear building module (70; 71) for according to any one of the preceding claims, **characterised in that** it comprises transversal elements (50), arranged transversely to said structural elements (11, 12).
7. Linear building module (70; 71) according to the preceding claim, **characterised in that** said transversal elements (50) cover two further lateral faces of said linear module (70; 71), thus connecting said perimeter elements (11).
8. Linear building module (70; 71) according to any one of the preceding claims, **characterised in that** it is comprised in a box-shaped element so as to define a further cavity comprising corrugated conduits for the passage of systems.
9. A kit comprising two linear modules (70; 71) according to any one of the preceding claims and coupling means (103; 104; 105; 106) for coupling said linear modules (70; 71) in a structural node comprising at least one horizontal beam (71) arranged along a horizontal plane and a vertical pillar (70) connected to said horizontal beam (71), said coupling means (103; 104; 105; 106) preferably being clamping elements (103), such as plates for beams (104) or for pillars (105; 106) or bolts.
10. Kit according to the preceding claim, comprising eight linear modules (70; 71) for forming a structural frame of at least one room comprising four structural nodes.
11. Kit according to either of claims 9 or 10 comprising at least one panel (1; 1b; 1c), for forming a vertical or horizontal wall of said building, in particular a self-supporting wall, wherein said at least one panel (1; 1b; 1c) comprises at least one internal cavity wherein said at least one filling element (20) made of thermally insulated material that fills said cavity, is arranged.
12. Kit according to claim 11, **characterised in that** said at least one panel (1; 1b; 1c) has the same internal structure as said linear module (70; 71).
13. Kit according to claim 11 or 12, **characterised in that** said at least one panel (1; 1b; 1c) comprises a cover layer comprising pipes and/or corrugated conduits for systems which can be connected to the pipes and/or corrugated conduits of other panels (1; 1b; 1c) and/or of said linear modules (70; 71).
14. Kit according to claim 13, **characterised in that** said cover layer of said panel (1; 1b; 1c) is removably coupled to the remaining part of said panel (1; 1b; 1c).

15. A thermically insulated multi-storey building, **characterised in that** it comprises a structural frame made by means of linear modules (70; 71) according to any one of claims 1-8, or by means of a kit according to any one of claims 9-14.

5

10

15

20

25

30

35

40

45

50

55

10

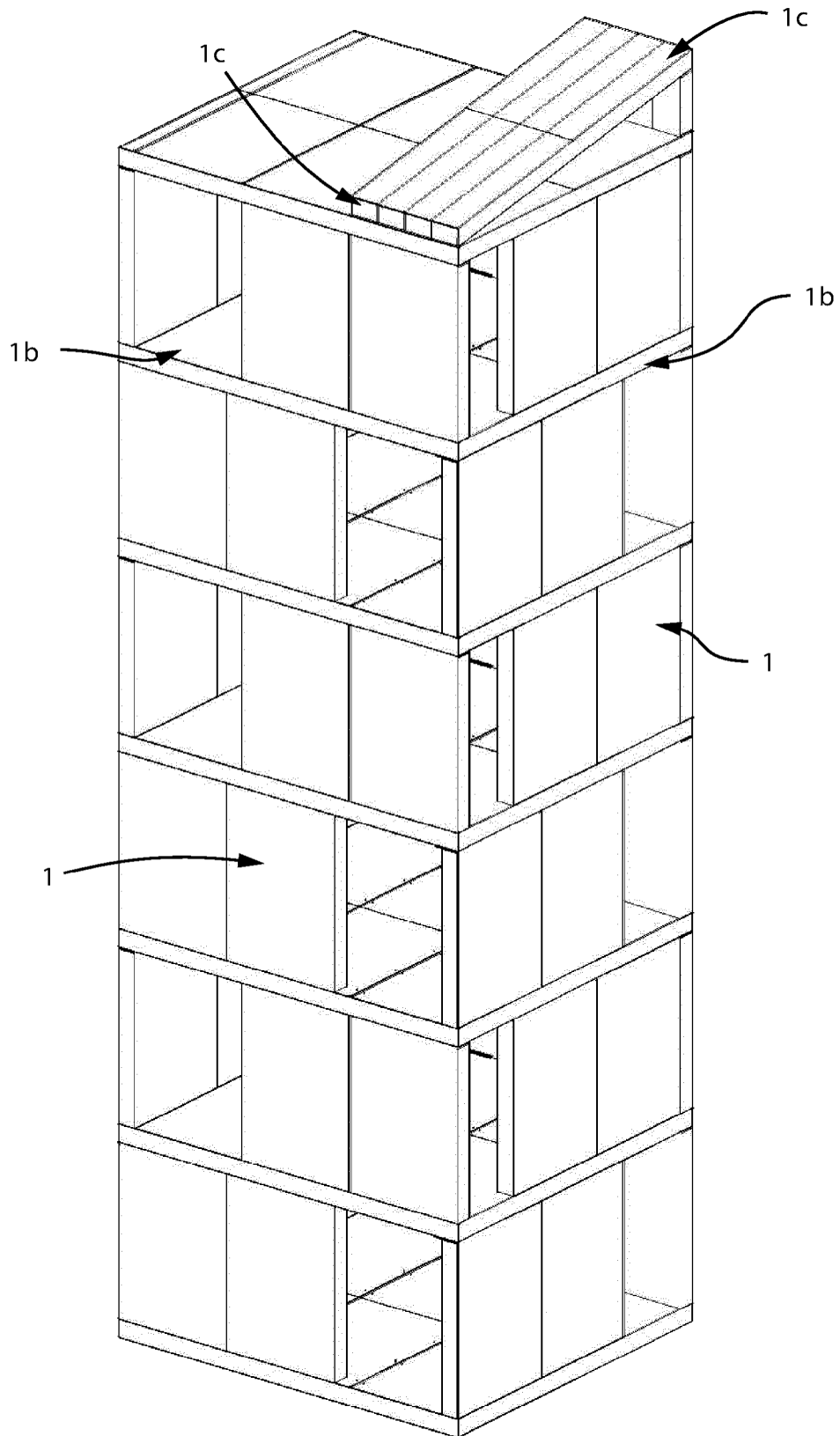

Fig. 1a

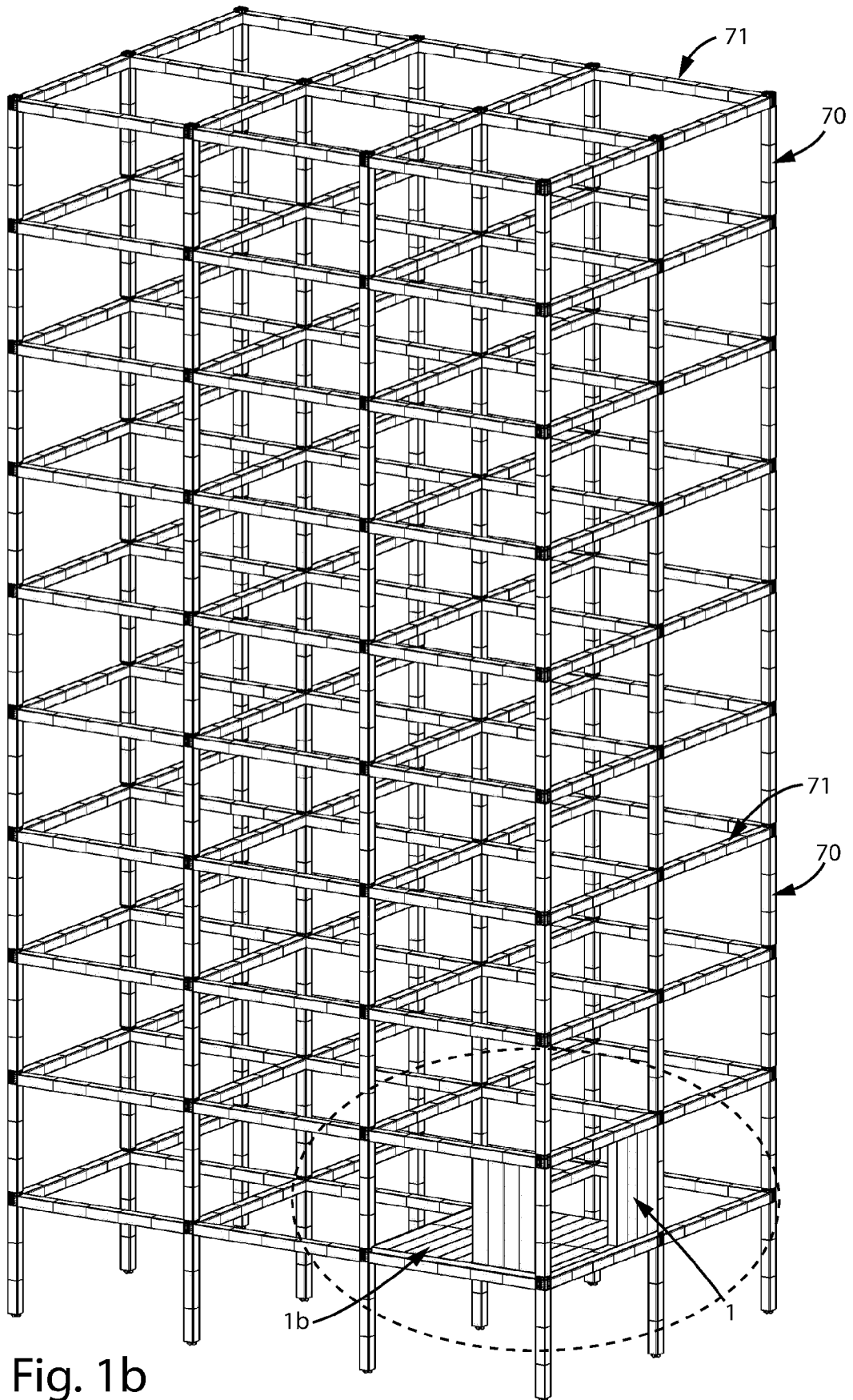

Fig. 1b

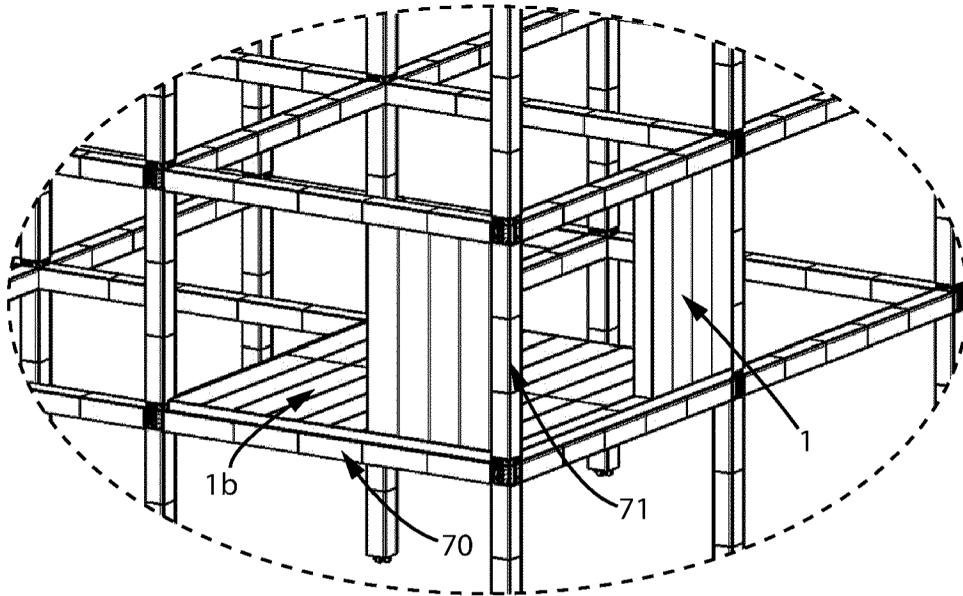

Fig. 1c

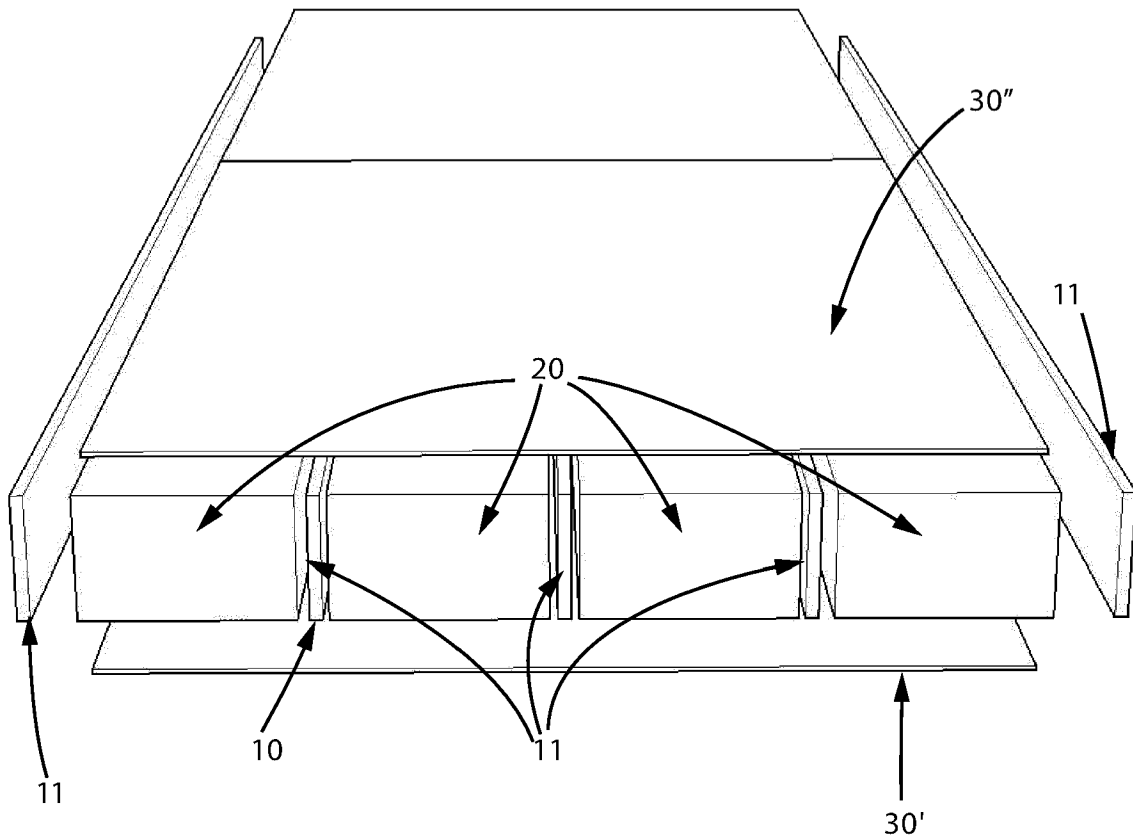

Fig. 2

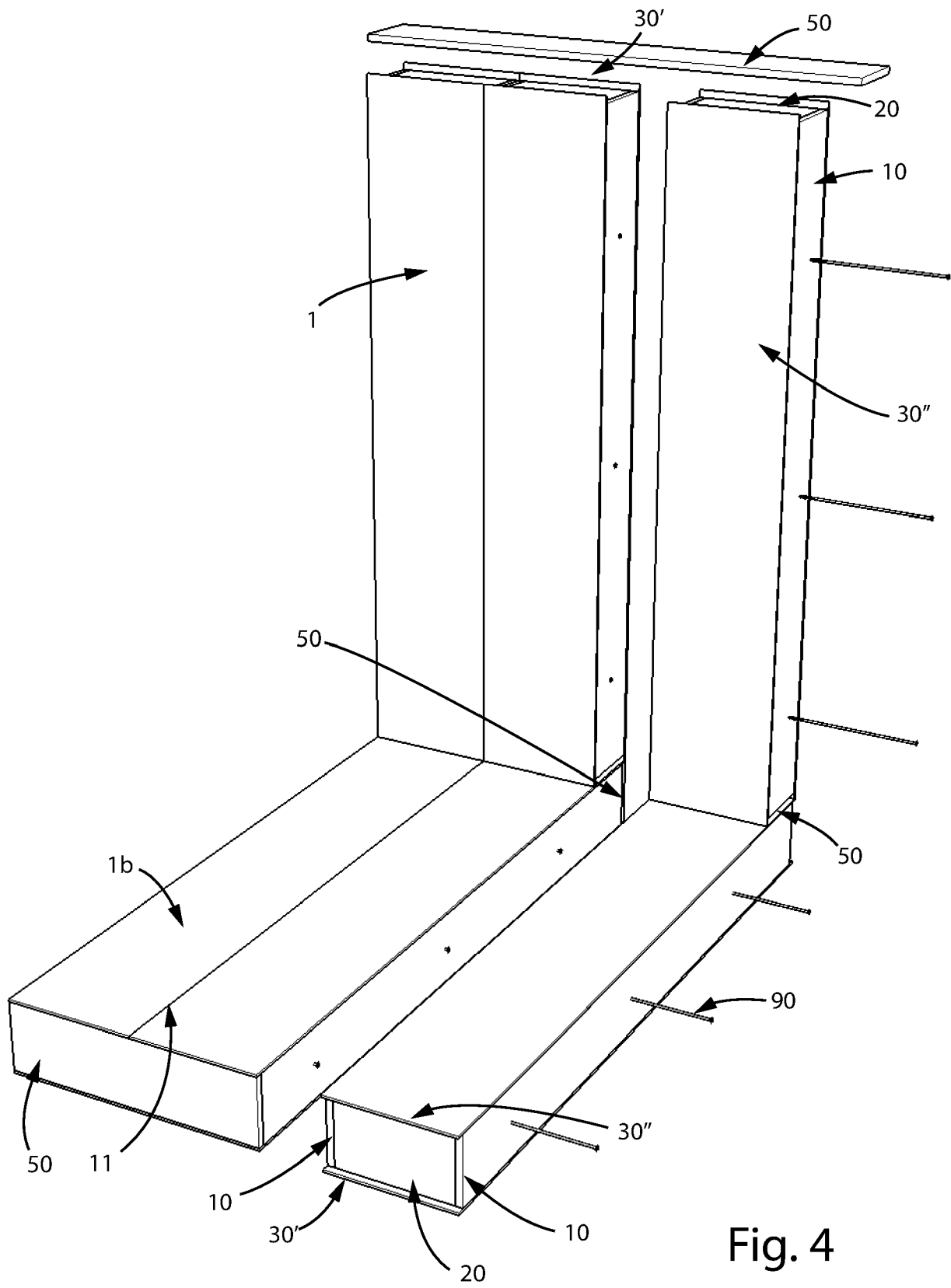

Fig. 4

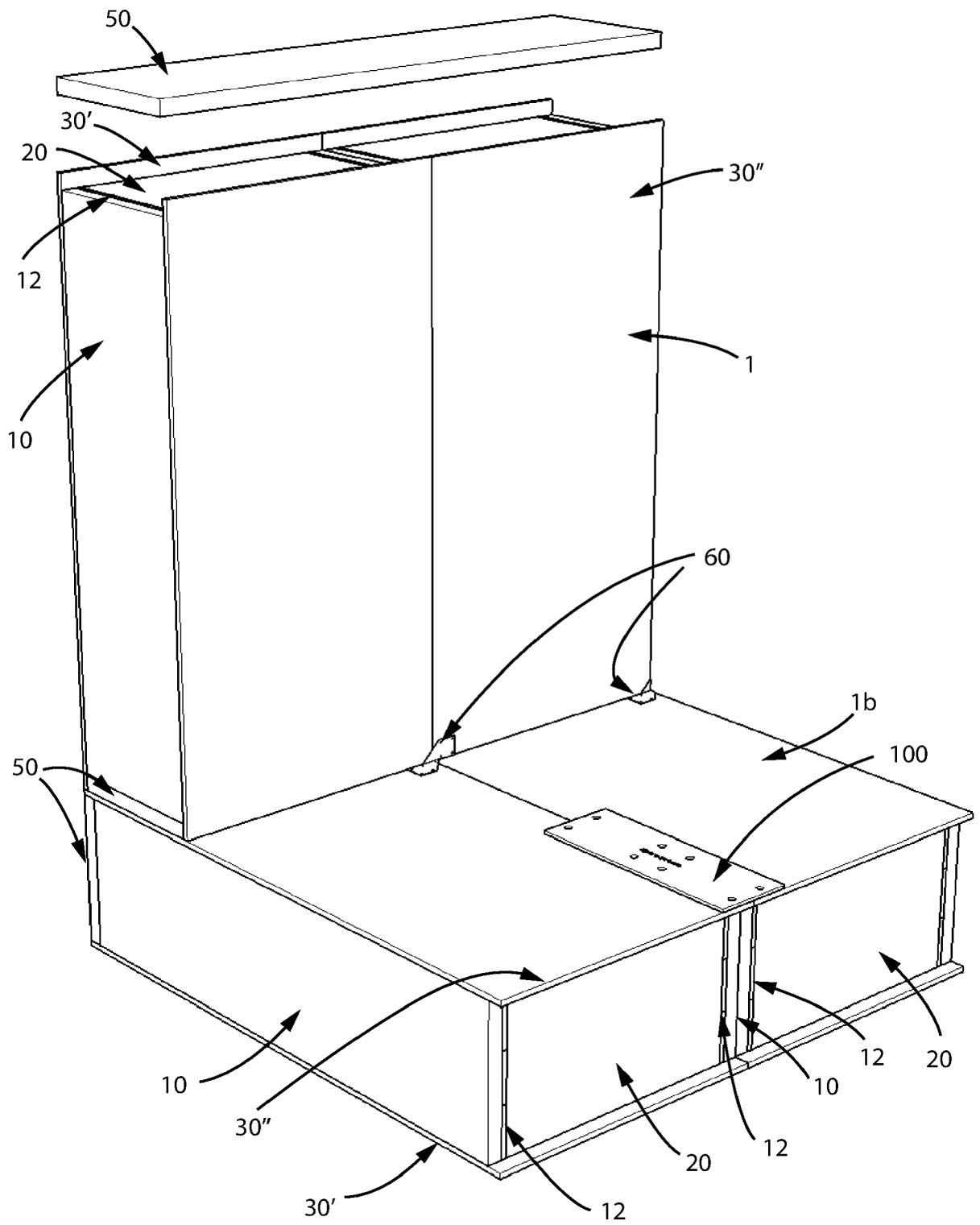

Fig. 5

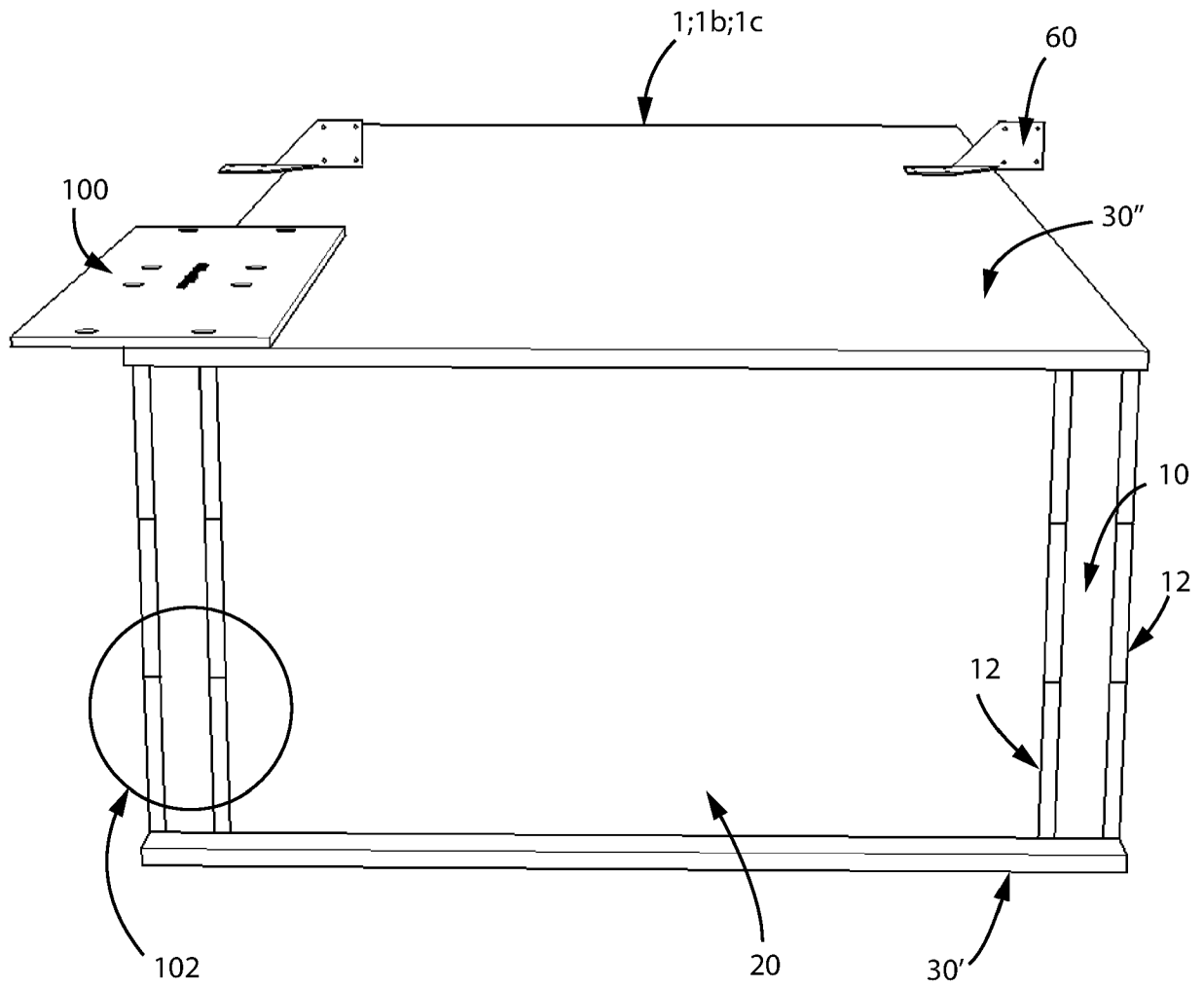

Fig. 6

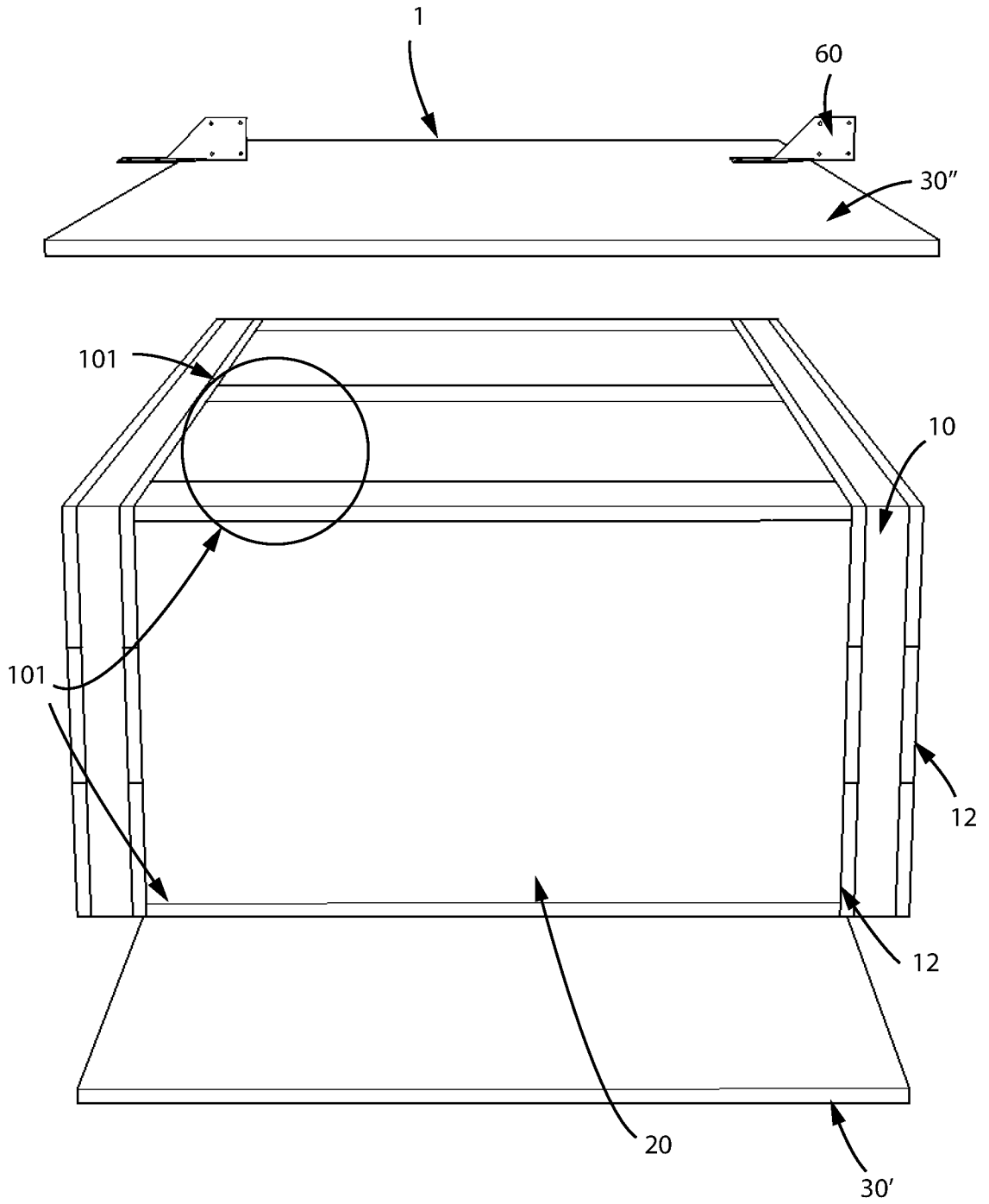

Fig. 7

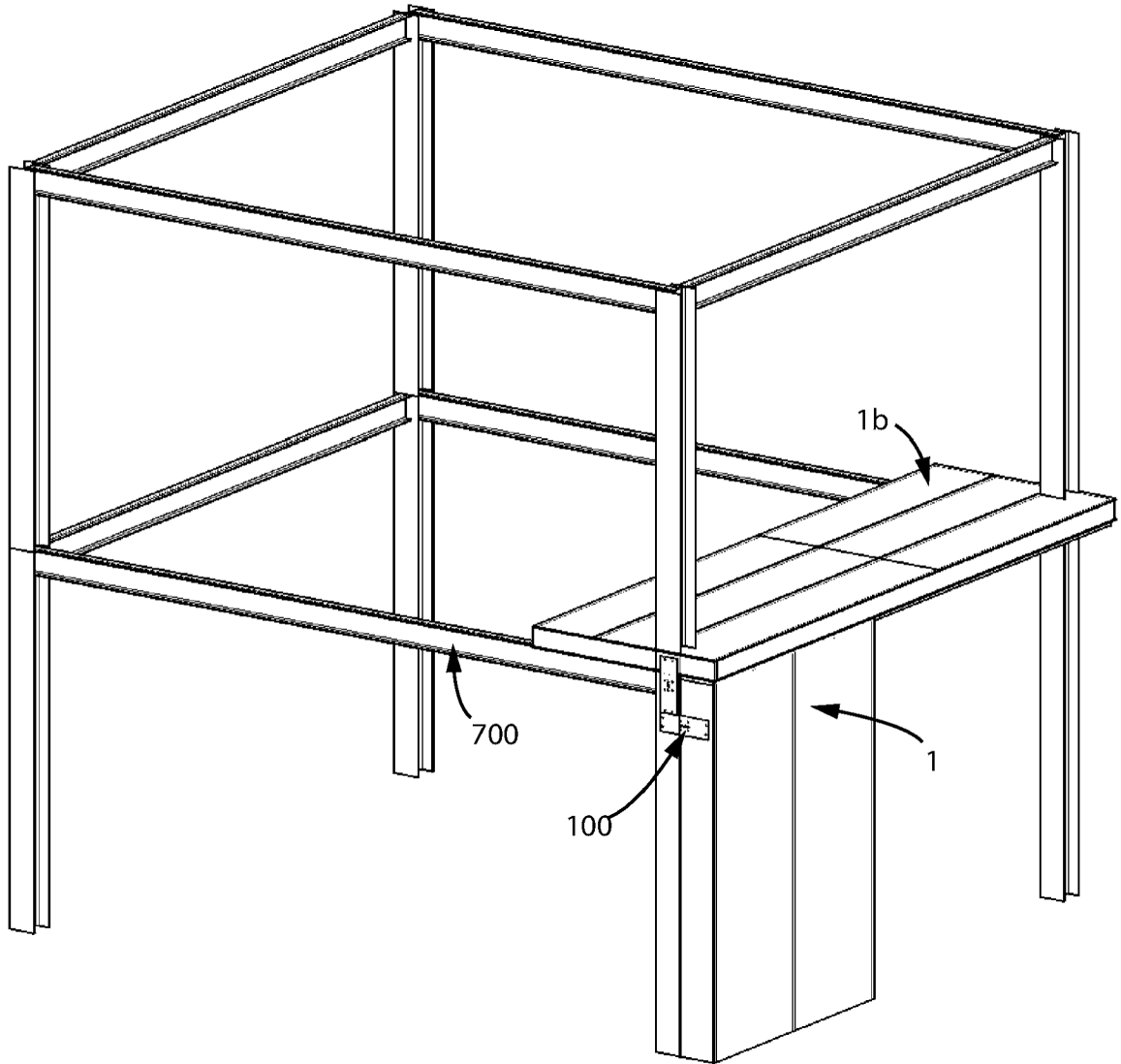

Fig. 8

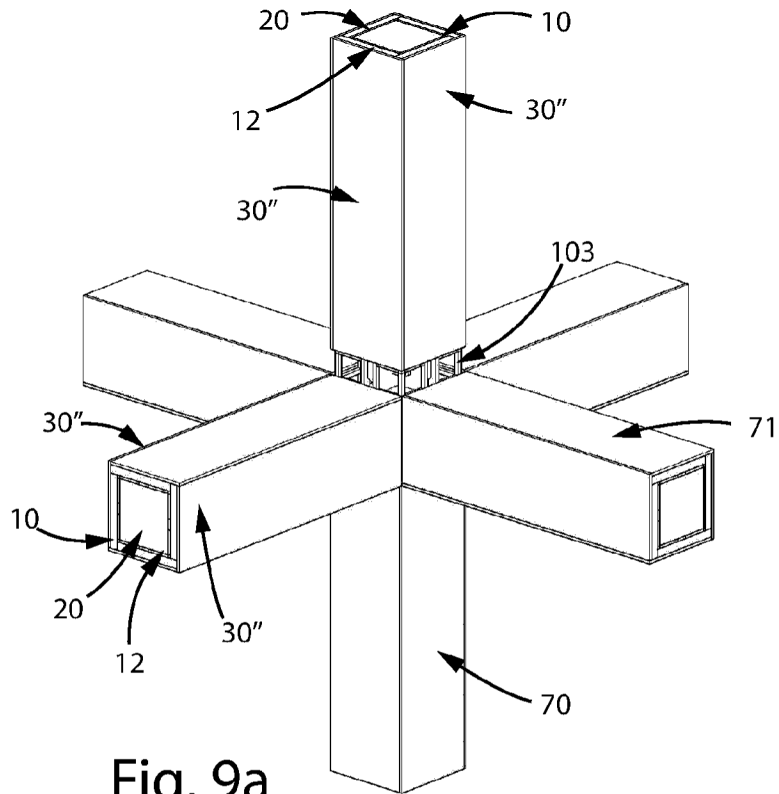

Fig. 9a

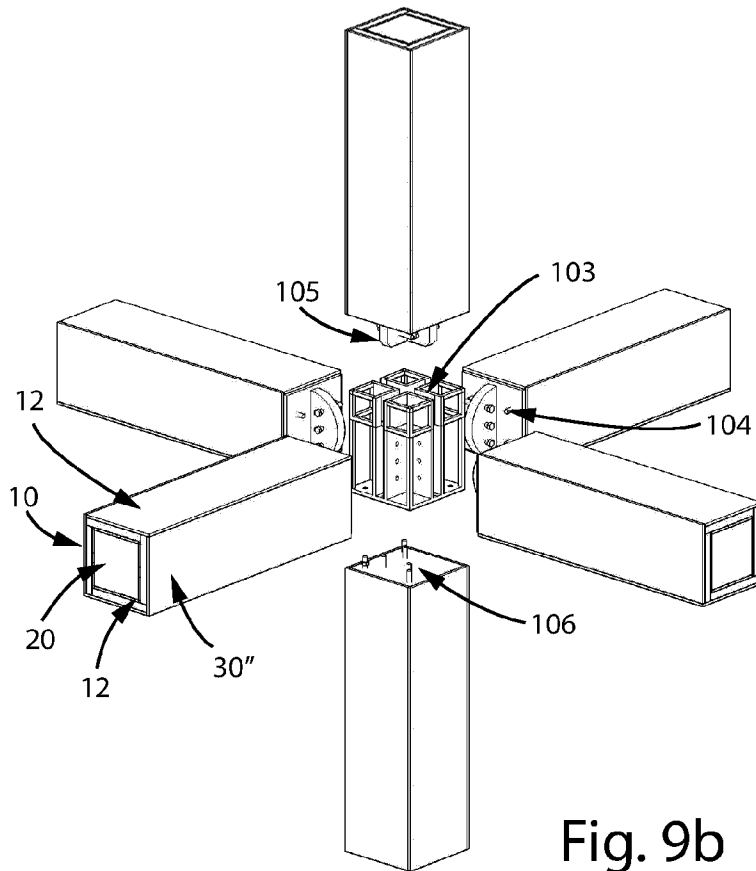

Fig. 9b

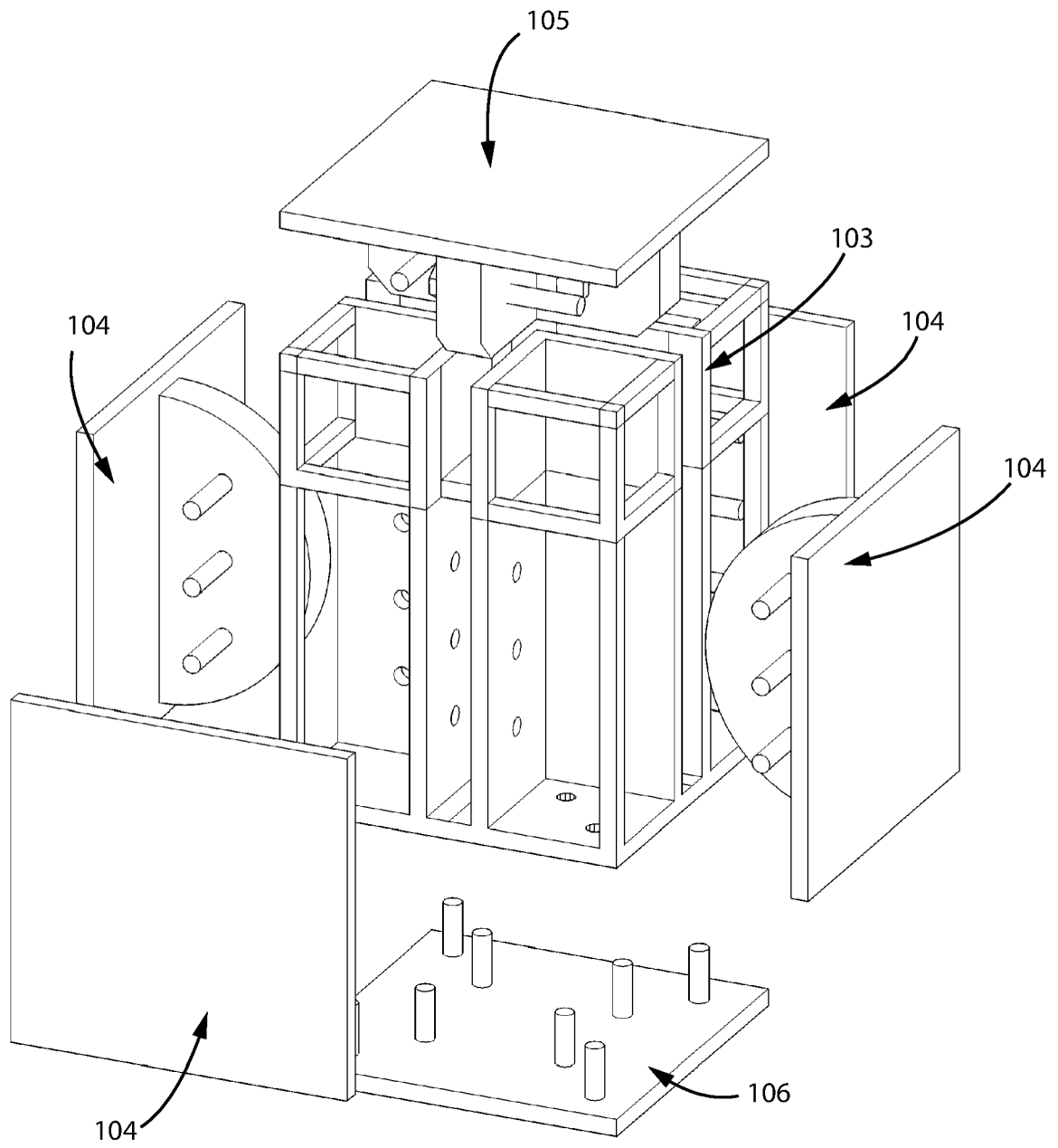

Fig. 10

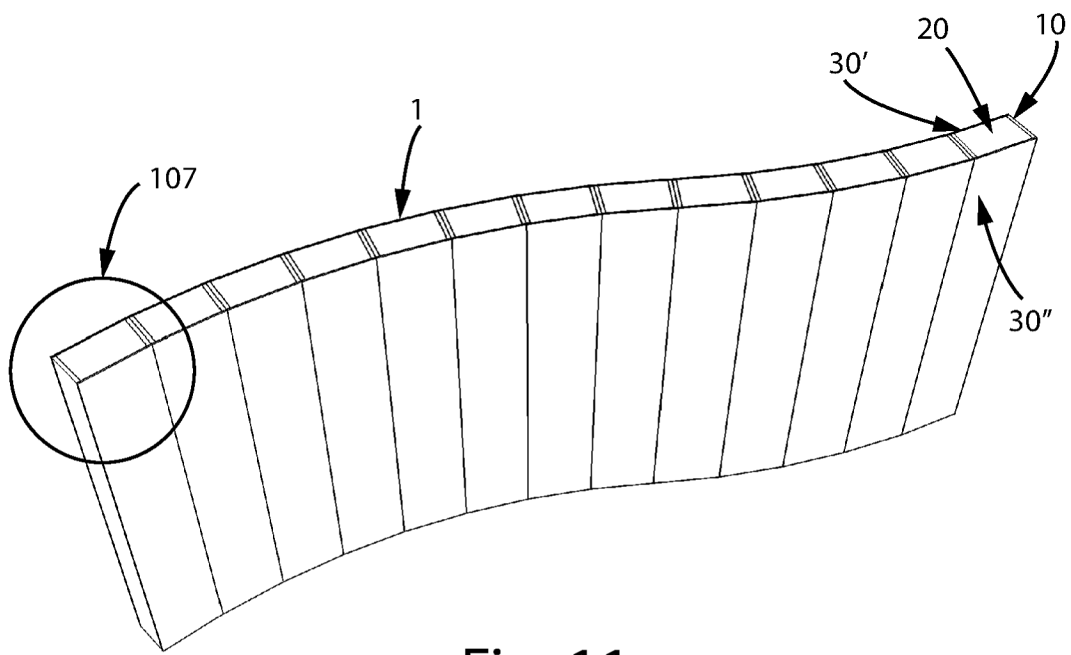

Fig. 11a

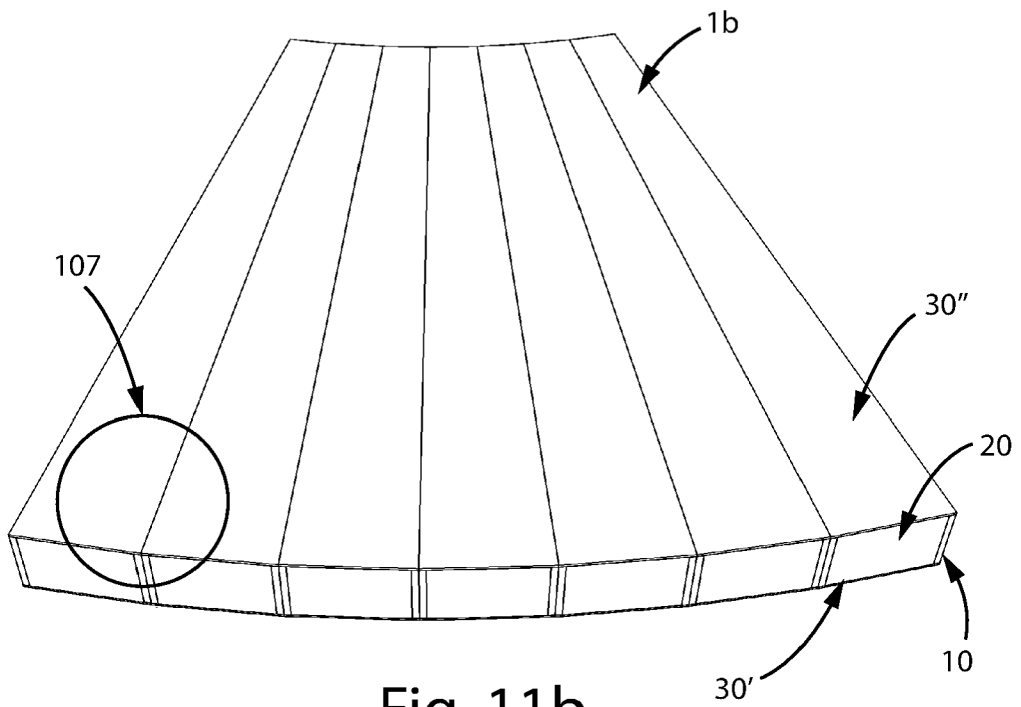

Fig. 11b

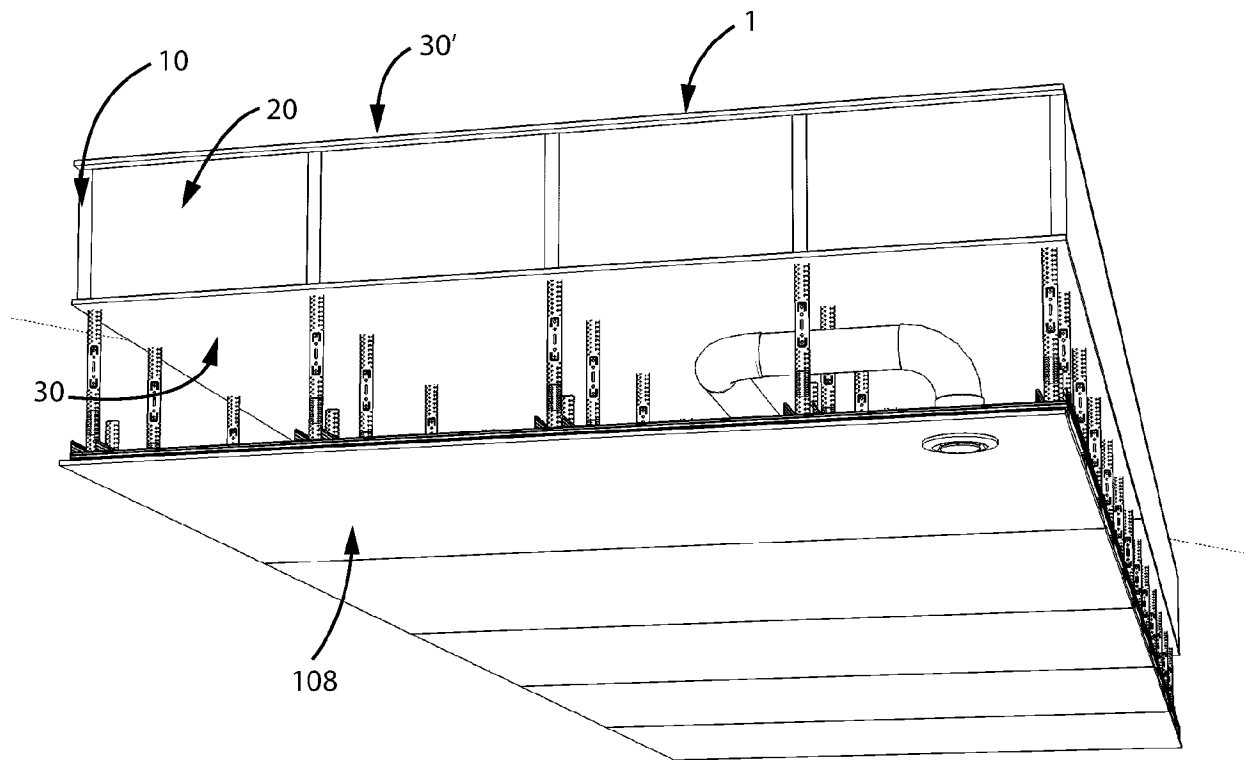

Fig. 12



EUROPEAN SEARCH REPORT

Application Number
EP 21 16 7474

5

10

15

20

25

30

35

40

45

50

55

DOCUMENTS CONSIDERED TO BE RELEVANT			
Category	Citation of document with indication, where appropriate, of relevant passages	Relevant to claim	CLASSIFICATION OF THE APPLICATION (IPC)
X	US 2018/274235 A1 (VIENS MAURICE [CA]) 27 September 2018 (2018-09-27) * figures 1-9 * * paragraph [0034] * -----	1-15	INV. E04B5/12 E04C3/12 E04C3/18 E04B2/70
X	FR 2 971 802 A1 (GOUTHERAUD GILBERT [FR]) 24 August 2012 (2012-08-24) * figures 1-14 * * page 4, line 31 - line 36 * -----	1-12	E04C3/36 E04C3/29 E04C3/292
X	WO 2015/121886 A1 (CASTELLI SETTIMIO [IT]) 20 August 2015 (2015-08-20) * figures 1-34 * -----	1-12	
			TECHNICAL FIELDS SEARCHED (IPC)
			E04B E04C
The present search report has been drawn up for all claims			
Place of search The Hague		Date of completion of the search 28 July 2021	Examiner Petrinja, Etiel
CATEGORY OF CITED DOCUMENTS X : particularly relevant if taken alone Y : particularly relevant if combined with another document of the same category A : technological background O : non-written disclosure P : intermediate document		T : theory or principle underlying the invention E : earlier patent document, but published on, or after the filing date D : document cited in the application L : document cited for other reasons & : member of the same patent family, corresponding document	

1
EPO FORM 1503 03 82 (P04C01)

ANNEX TO THE EUROPEAN SEARCH REPORT
ON EUROPEAN PATENT APPLICATION NO.

EP 21 16 7474

5

This annex lists the patent family members relating to the patent documents cited in the above-mentioned European search report. The members are as contained in the European Patent Office EDP file on The European Patent Office is in no way liable for these particulars which are merely given for the purpose of information.

28-07-2021

10

Patent document cited in search report	Publication date	Patent family member(s)	Publication date
US 2018274235 A1	27-09-2018	CA 2999557 A1 US 2018274235 A1	27-09-2018 27-09-2018
FR 2971802 A1	24-08-2012	NONE	
WO 2015121886 A1	20-08-2015	AU 2015216546 A1 CA 2922944 A1 CN 106030004 A DK 2997203 T3 EP 2997203 A1 LT 2997203 T US 2016222643 A1 WO 2015121886 A1 ZA 201606237 B	11-08-2016 20-08-2015 12-10-2016 13-03-2017 23-03-2016 12-06-2017 04-08-2016 20-08-2015 31-05-2017

15

20

25

30

35

40

45

50

55

EPO FORM P0459

For more details about this annex : see Official Journal of the European Patent Office, No. 12/82

REFERENCES CITED IN THE DESCRIPTION

This list of references cited by the applicant is for the reader's convenience only. It does not form part of the European patent document. Even though great care has been taken in compiling the references, errors or omissions cannot be excluded and the EPO disclaims all liability in this regard.

Patent documents cited in the description

- EP 2920377 B1 **[0008]**
- IT 102015000077457 **[0016]**
- IT UB20155972 A1 **[0016]**
- US 10196809 B2 **[0020]**
- EP 0237044 A1 **[0022]**
- US 4187655 A **[0022]**
- EP 2149645 A1 **[0022]**
- US 8161699 B2 **[0022]**
- WO 2015071821 A1 **[0023] [0131]**